

Model: P24 Series

240 kA Per Phase*
with Sinewave Tracking
ANSI/UL 1449
Type 1 SPD (no filter), I_n = 20 kA
Type 2 SPD (filter), I_n = 20 kA



* Based on 3 Phase Wye, 4 Wire and Ground
I_n = Nominal Discharge Current per ANSI/UL 1449-2006

Key Features

- **Discrete “All Mode” Circuitry: Directly Connected Protection Elements in “All Modes” (10 modes for 3 phase Wye circuits) as recommended by ANSI/IEEE Std. 1100-2005**
- **Industry Leading Measured Limiting Voltage (let-through) Performance**
- **Multi-stage Hybrid Frequency Responsive Circuitry**
- **Local & Remote Diagnostics**
- **Independent Verification of Performance and Safety**
- **No moving parts or springs - No mechanical or electro-mechanical thermal/over-current protection**
- **Component-Level, Thermal Fusing**
- **Patented Internal, Circuit Board Mounted, Over-Current Fusing**
- **25 Year Unlimited Free Replacement Warranty**



PANELGUARD® INTERMATIC®

Application: The P24 series is the workhorse of our product line. This durable, high performance single port device is intended for sensitive and critical load applications at service entrance locations, main distribution panels, motor control centers, and individual equipment.

ANSI/IEEE C62.41.1 & C62.41.2-2002 environments: Suitable for Categories: A, B & C (Most Severe Electrical Environments)

IEC Environments: Suitable for use in IEC 61643-11 environments

Circuit Topology: Parallel configured combination **Frequency Responsive Circuitry** and **Voltage Responsive Circuitry** circuit design incorporating component-level, thermal fusing and circuit board mounted, **Patented** internal over-current fusing methodology with discrete “**All Mode**” protection (10 modes for 3 phase Wye units). All protection circuits are encapsulated in our high-dielectric compound to promote long component life and protection from the weather and vibration.

Protection Modes: Industry-best practice of dedicated protection components for all operational modes of the electrical system. **Discrete L-N, L-L (Normal Mode) and L-G, N-G (Common Mode)** Example: Directly Connected Protection Elements in All 10 modes for a 3 phase, 4 wire, Wye systems, (i.e., 3 L-N modes, 3 L-L modes, 3 L-G modes and 1 N-G mode).

Input Power: 50-60 Hz (60 Hz nominal)

Temperature Rating: Up to 80°C

Insertion Loss Data: (L-N)

Frequency:	10 kHz	100 kHz	1 MHz	Max Attenuation & Freq.
Attenuation:	20 dB	52 dB	21 dB	55 dB @ 106 kHz

Standard Enclosure: NEMA 4x Rated Standard Enclosure

Nominal Discharge Current (I_n) Rating: 20 kA

(*Complies with the requirements of UL 96A Master Label for Installation Requirements for Lightning Protection Systems)

Diagnostics: Blue LED's, one per phase, normally on. A wide range of optional diagnostics is available (see page two for details).

Circuit Interrupt: Internal component-level, thermal fusing and patented circuit board mounted, over-current fusing. No external over-current protection required. Note: National and local codes may require the use of a circuit interrupt device(s) if conduit is added to make the wired connection to the panel or gear.)

Short Circuit Current Rating: 200 kAIC

Product Qualifications:

Listed to ANSI/UL 1449 by UL (E340498), CSA (MC#241804); UL1283 ISO 9001 Certified Manufacturing Facility by NQA

Voltage Code	ANSI/UL 1449 Voltage Protection Rating (VPR)						
	L-N	HL-N	L-G	HL-G	N-G	L-L	HL-L
1S1	600	-	600	-	700	1000	-
3Y1	600	-	600	-	700	1000	-
3D1	600	1200	600	1200	700	1000	1000
3Y2	1200	-	1200	-	1200	1800	-
3N2	-	-	1200	-	-	1000	-
3N4	-	-	1800	-	-	1800	-

Voltage Code*	Circuit Type	Peak Surge Current	MCOV	ANSI/IEEE C62.41.2™-2002, C62.45™-2000 and C62.62™-2010 Measured Limiting Voltages (tested with 6 inches of lead length external to the enclosure per C62.62™-2010 and ANSI/UL 1449)		
				Test Mode	Cat A, 30 Ω 100 kHz Ring Wave 2 kV / 67 A @ 270° Phase Angle	Category C (High) 10 kA 8/20 Current Driven Test†
1S1	120/240 V 1Ø (Split) (3 wire + ground)	80 kA L-N	150 V	L-N	27 V	1,068 V
		80 kA L-L	300 V	L-L	35 V	1,381 V
		80 kA L-G	150 V	L-G	60 V	1,048 V
		80 kA N-G	150 V	N-G	60 V	1,431 V
		480 kA Total				
3Y1	120/208 V 3Ø Wye (4 wire + ground)	80 kA L-N	150 V	L-N	27 V	1,068 V
		80 kA L-L	300 V	L-L	35 V	1,381 V
		80 kA L-G	150 V	L-G	60 V	1,048 V
		80 kA N-G	150 V	N-G	60 V	1,431 V
		800 kA Total				
3D1	120/240 V 3Ø High-Leg Delta (4 wire + ground)	80 kA L-N	150 V	L-N	27 V	1,068 V
		80 kA HL-N	320 V	HL-N	57 V	1,334 V
		80 kA L-L	300 V	L-L	35 V	1,381 V
		80 kA L-G	150 V	L-G	60 V	1,048 V
		80 kA HL-G	320 V	HL-G	77 V	1,304 V
		80 kA N-G	150 V	N-G	60 V	1,431 V
		800 kA Total				
3Y2	277/480 V 3Ø Wye (4 wire + ground)	80 kA L-N	320 V	L-N	57 V	1,334 V
		80 kA L-L	550 V	L-L	63 V	1,981 V
		80 kA L-G	320 V	L-G	77 V	1,304 V
		80 kA N-G	320 V	N-G	69 V	1,721 V
		800 kA Total				
3N2	240 V 3Ø Delta (NN) (3 wire + ground)	80 kA L-L	320 V	L-L	35 V	1,381 V
		80 kA L-G	320 V	L-G	1,104 V	1,304 V
		480 kA Total				
3N4	480 V 3Ø Delta (NN) (3 wire + ground)	80 kA L-L	550 V	L-L	104 V	1,981 V
		80 kA L-G	550 V	L-G	1,559 V	2,144 V
		480 kA Total				

Measured Limiting Voltage (MLV) Test Parameters: Positive polarity, Category A: Line power applied, Category C: No line power applied, Voltages are peak (±10%). Measured Limiting Voltages are measured from the insertion point on the sine wave to the peak of the surge for powered tests. Each MLV is the average of all phases within that mode of protection. To duplicate the results, the specified mode of protection must be tested in all phases (except N-G) and averaged together. (Individual mode or shot results may vary by more than 10%). Scope Settings: Time Base = 10 microseconds per division, Sampling Rate = 2.5 Gigasamples/sec, Bandwidth = 400 MHz (200 MHz for Cat. C), Probes: Tektronix P5100/P6015A. These settings help to assure MLV results are accurate). **All tests performed with 6" lead length (external to the enclosure), simulating actual installed performance.** The MLVs reported above are certified by Third-Party, Independent Testing. Individual test reports are available upon request.

†The MLV reported for the Category C High, 10 kA 8/20 Current Driven Test is determined by measuring the MLV of one of the fifteen 10 kA impulses impressed through the SPD during the Nominal Discharge Current (In) Test from C62.62™-2010 and ANSI/UL 1449-2006. This is not the MLV recorded during the pre- and/or post-test 6 kV / 3 kA Combination Wave Test used to determine the VPR of the SPD. The VPRs are reported on page 1 of this specification.

*Other voltage configurations may be available. Contact your sales representative for additional assistance.

Model Number Example: P24T23Y2DG3

Base Model:	Modes of Protection:	Advanced Filtering:	Voltage Codes:	Options:
P24 = 240 kA	T = Ten	1=No Filter 2=Filter	See Voltage Codes 3Y2	See Option codes DG3

- DG1** = Blue LED's, one per phase, normally ON
- DG2⁽¹⁾** = DG1 package plus: Audible internal alarm, Form C relay with External wires.
- DG3⁽¹⁾** = DG2 package plus: surge counter with reset button
- DG4⁽¹⁾** = DG3 package plus: Panel mount alarm mute and test switches
- ⁽¹⁾ = With Form C Dry Relay Contacts.
- D1 (CSA)** = Integral, non-fused disconnect switch (SPD unit mounts inside)
- D3 (CSA)** = Same as **D1**, except no external handle
- LP** = Remote LED and overlay kit
- P** = Flush Mount Plate
- Standard Enclosure** = NEMA 4X Composite Enclosure
- 24** = 24" wire leads
- 36** = 36" wire leads
- 48** = 48" wire leads
- 60** = 60" wire leads
- Standard Wire Length** = 18" wire leads

Enclosure Dimensions			
Inches (mm)	DG1 Option	DG2-4 Option	D1 or D3 Option
	No Disconnect	No Disconnect	D1 or D3 Disconnect
A	8.74 (222)	11.25 (286)	13.25 (337)
B	5.25 (133)	9.04 (230)	12.50 (318)
C	3.31 (84)	7.72 (196)	7.72 ⁽¹⁾ (196)
D	10.24 (260)	12.25 (311)	14.25 (362)
E	11.05 (281)	13.06 (332)	15.21 (386)
G	9.24 (235)	11.25 (286)	13.25 (337)
H	3.87 (98)	5.50 (140)	7.50 (191)
Type	NEMA 4X Composite		
lbs. (kg)	5.00 (2.27)	7.63 (3.46)	17.98 (8.16)

⁽¹⁾ This dimension is 9.46 in. (240mm) when option 1, external disconnect, is selected.

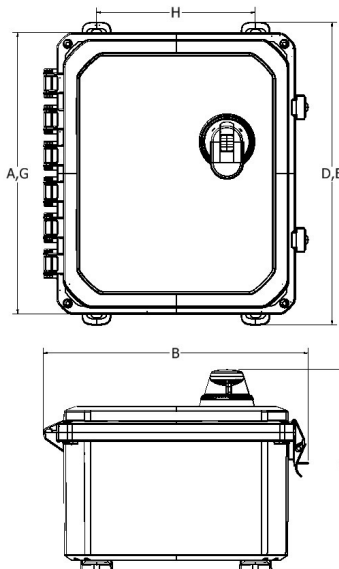

Circuit Connection: #10 AWG wire (pre-installed)