



**M6 Series**  
**60 kA Per Phase**  
**Peak Surge Current**  
**ANSI/UL1449 UL Fourth Edition**  
**Type 1 SPD (no filter), I<sub>n</sub> = 20 kA**  
**Type 2 SPD (filter), I<sub>n</sub> = 20 kA**

Designed specifically for the new construction and “bid spec” market place, the M6 series of Surge Protective Devices provides the features, performance and value required by discriminating specifying engineers. This device is intended for protection of general-purpose load applications ranging from individual equipment disconnects and sub panels to distribution panels and service entrance locations. It is extremely effective in limiting lightning surges as well as internally generated transients.

The M6 series provides an effective blend of leading-edge suppression design technology, straight forward, no frills engineering and customer driven, value added options. Specify PANELGUARD with confidence.

**Description:** Parallel connected, AC power Surge Protective Device.

**Application:** Designed for use at ANSI/IEEE C62.41.1 & C62.41.2 location categories C, B and A. Designed to protect all types of loads fed from individual disconnects, sub panels, distribution panels and service entrance locations.

**Warranty:** 15 Years

**Unit Listings:** Listed to ANSI/UL 1449 by UL (E315947), CSA (MC#241804); UL1283\* (\* Type 2 SPDs only)

**Circuit Design:** Parallel connected, hybrid circuit design incorporating both component level thermal fusing and internal over-current fusing. All protection circuits are encapsulated in our high dielectric compound to promote long component life and protection from the weather and vibration.

**Directly Connected Protection Modes:** All Mode - L-L, Discrete L-N (Normal Mode), and Discrete L-G, N-G (Common Mode).

**Input Frequency:** 50-420 Hz (60 Hz typical)

**Insertion Loss Data: (L-N for 3Y1)**  
 Frequency: 280 kHz    1 MHz    Max Attenuation & Freq.  
 Attenuation:    3 dB    17 dB    40 dB @ 483 kHz

**EMI/RFI Filtering:** Up to 41 db normal mode, 39 db common mode

**Circuit Diagnostics:** Super Bright LED, 1 per phase, normally on. See pg. 2 for additional diagnostics options

**Connection/mounting:** #10 Wire (pre-installed), hub (pre-installed on base models, installed at time of installation on optional enclosures) and integral, multi-point mounting feet.

**Circuit Interrupt:** Internal component-level, thermal fusing and patented circuit board mounted, over-current fusing. No external over-current protection required. (Note: National and local codes may require the use of a circuit interrupt device(s) if conduit is added to make the wired connection to the panel or gear.) SCCR = 200 kA

**Nominal Discharge Current (I<sub>n</sub>) Rating:** 20 kA\*\* (\*\* Complies with the requirements of UL 96A Master Label for Installation Requirements for Lightning Protection Systems)



- Industry Leading Measured Limiting Voltage Performance
- Independent Verification of Performance and Safety
- Component-Level, Thermal Fusing and Over-Current Fusing
- No moving parts or springs - No mechanical or electro-mechanical thermal/over-current protection
- Circuit Encapsulation

Voltage Code	ANSI/UL 1449 (Fourth Edition) Voltage Protection Rating (VPR)						
	L-N	HL-N	L-G	HL-G	N-G	L-L	HL-L
1P1	600	-	600	-	600	-	-
1S1	600	-	600	-	600	1200	-
3Y1	600	-	600	-	600	1200	-
3D1	600	1000	600	1200	600	1200	1800
3Y2	1000	-	1200	-	1200	2500	-
3N4	-	-	1800	-	-	1800	-



Options	Description
DG1	LED Indicators
DG2 <sup>(1)</sup>	Basic Internal Audible Alarm
DG3 <sup>(1)</sup>	Basic Alarm/ Surge Counter
DG4 <sup>(1)</sup>	Advanced Alarm w/ surge counter on, off, and test
(1)	Form C Dry Relay Contacts (With DG2, DG3 & DG4 options)
D1 (CSA)	Integral Disconnect Switch **
D3 (CSA)	Integral Disconnect Switch (no external handle) **
-LP	Remote LEDs in liquid tight holders
P	Flush Mount Plate
Standard Enclosure	NEMA 4X Composite Enclosure
24	24" wire leads
36	36" wire leads
48	48" wire leads
60	60" wire leads
Standard Wire Length	18" wire leads

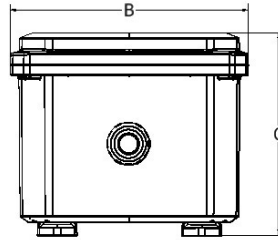
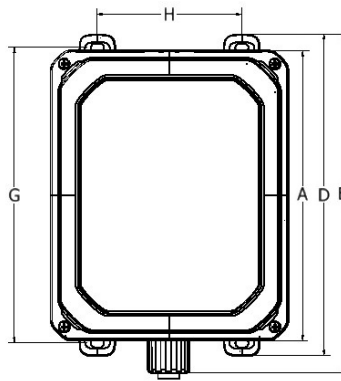

Enclosure Dimensions			
Inches (mm)	DG1 Option	DG2-4 Option	DG1-4 Option
	No Disconnect	No Disconnect	D1 or D3 Disconnect
A	8.74 (222)	11.25 (286)	13.25 (337)
B	5.25 (133)	9.04 (230)	12.50 (318)
C	3.31 (84)	7.72 (196)	7.72 <sup>(1)</sup> (196)
D	10.24 (260)	12.25 (311)	14.25 (362)
E	11.05 (281)	13.06 (332)	15.21 (386)
G	9.24 (235)	11.25 (286)	13.25 (337)
H	3.87 (98)	5.50 (140)	7.50 (191)
Type	NEMA 4X Composite		
lbs. (kg)	5.00 (2.27)	7.63 (3.46)	14.19 <sup>(2)</sup> (6.44)

<sup>(1)</sup> This dimension is 9.46 in. (240mm) when option D1, external disconnect, is selected.

<sup>(2)</sup> The weight is 17.98 lbs. (8.16kg), when option D1 or D3 is selected.

Model Number Example: M6S23Y2DG3

Base Model:	Modes of Protection:	Advanced Filtering:	Voltage Codes:	Options:
M6 = 60 kA	S = Seven	1=No Filter 2=Filter	See Voltage Codes 3Y2	See Option codes DG3

### MEASURED LIMITING VOLTAGE PERFORMANCE AND ELECTRICAL SPECIFICATIONS

Voltage Code*	Circuit Type	Peak Surge Current (Amps) Per Mode & Per Phase	MCOV	ANSI/IEEE C62.41.1 <sup>TM</sup> -2002, C62.41.2 <sup>TM</sup> -2002, C62.45 <sup>TM</sup> -2002, and C62.62 <sup>TM</sup> -2010 Measured Limiting Voltages (tested with 6 inches of lead length external to the enclosure per Clauses 6.1.1 of C62.62 <sup>TM</sup> -2010 and 37.4.4 of ANSI/UL 1449-2006)		
				Test Mode	Cat A 30 Ω 100 kHz Ring Wave 6 kV 200 A @ 90° Phase Angle	Category C (High) 10 kA 8/20 Current Driven Test <sup>†</sup>
1S1	120/240 V, Split Ø (3 wire + ground)	30,000 Per Mode (L-L, L-N, L-G, N-G) 60,000 Per Phase	320 150 150 150	L-L L-N L-G N-G	484 V 310 V 338 V 615 V	1,381 V 1,068 V 1,048 V 1,431 V
1S2	220/380 V 1Ø (Split) (3 wire + ground)	30,000 Per Mode (L-L, L-N, L-G, N-G) 60,000 Per Phase	550 320 320 320	L-L L-N L-G N-G	527 V 430 V 419 V 956 V	1,981 V 1,334 V 1,304 V 1,721 V
3Y1	120/208 V, 3ØY (4 wire + ground)	30,000 Per Mode (L-L, L-N, L-G, N-G) 60,000 Per Phase	320 150 150 150	L-L L-N L-G N-G	484 V 310 V 338 V 615 V	1,381 V 1,068 V 1,048 V 1,431 V
3D1	120/240 V, 3ØΔ (4 wire + ground)	30,000 Per Mode (L-L, L-N, HL-N, L-G HL-G, N-G) 60,000 Per Phase	320 150 320 150 320 150	L-L L-N HL-N L-G HL-G N-G	484 V 310 V 430 V 338 V 419 V 615 V	1,381 V 1,068 V 1,334 V 1,048 V 1,304 V 1,431 V
3Y2	277/480 V, 3ØY (4 wire + ground)	30,000 Per Mode (L-L, L-N, L-G, N-G) 60,000 Per Phase	550 320 320 320	L-L L-N L-G N-G	527 V 430 V 419 V 956 V	1,981 V 1,334 V 1,304 V 1,721 V
3N2	240 V, 3ØΔ (3 wire + ground)	30,000 Per Mode (L-L, L-G) 60,000 Per Phase	320 320	L-L L-G	484 V 419 V	1,381 V 1,304 V
3N4	480 V, 3ØΔ (3 wire + ground)	30,000 Per Mode (L-L, L-G) 60,000 Per Phase	550 550	L-L L-G	505 V 505 V	1,981 V 2,144 V

**Measured Limiting Voltage (MLV) Test Parameters:** Positive polarity, Category A: Line power applied, Category C: No line power applied, Voltages are peak (±10%). Measured Limiting Voltages are measured from the insertion point on the sine wave to the peak of the surge for powered tests. Each phase is the average of the modes within that mode of protection. In order to duplicate the results, the specified mode of protection must be tested in all modes (except N-G) and averaged together. (Individual mode or shot results may vary by more than 10%. Scope Settings: Time Base = 10 microseconds per division, Sampling Rate = 2.5 Giga-samples/sec, Bandwidth = 400 MHz (200 MHz for Cat C), Probes: Tektronix P5100/P6015A. These settings help to assure MLV results are accurate). **All tests performed with 6" lead length (external to the enclosure), simulating actual installed performance.** The MLVs reported above are certified by Third-Party, Independent Testing. Individual test reports are available upon request.

<sup>†</sup>The MLV reported for the Category C High, 10 kA 8/20 Current Driven Test is determined by measuring the MLV of one of the fifteen 10 kA impulses impressed through the SPD during the Nominal Discharge Current (In) Test from C62.62<sup>TM</sup>-2010 and ANSI/UL 1449-4<sup>th</sup> Edition. This is not the MLV recorded during the pre- and/or post-test 6 kV / 3 kA Combination Wave Test used to determine the VPR of the SPD. The VPRs are reported on page 1 of this specification.

\*Other voltage configurations may be available. Contact your sales representative for additional assistance.