



# PANELGUARD® M & P Series SPDs

Three Phase Delta, 4-Wire Suppressors with  
Internal Fusing (3 Phases and Ground)

## Installation Instructions

### **! WARNING** Risk of Fire or Electric Shock

- **HAZARDOUS VOLTAGES ARE PRESENT.** Improper installation may result in serious injury to the installer and/or damage to the electrical system or related equipment. Read all instructions before beginning the installation. Safety equipment must be used as prescribed by OSHA, whenever working around hazardous voltages.
- **Failure of unit and/or consequential equipment damage due to improper installation or misapplication is not covered by the product warranty.**
- Voltage measurements and **installation must be completed by a licensed/qualified electrician** in accordance with the National and/or Canadian Electric Code, State, and Local codes. These requirements supersede this instruction.

### **NOTICE**

- **POWER MUST BE REMOVED FROM THE ELECTRICAL SYSTEM BEFORE INSTALLING THE UNIT.**

## INSTALLATION MATERIALS REQUIRED

The following is a list of materials that may be needed for proper installation of this Surge Protective Device (SPD). This list is intended to help the installer anticipate materials needed for a successful installation. The installer should become familiar with the scope of work to avoid lost time and improper installation. Failure to use fittings that are "Listed" will void the "Listing" of the SPD.

- For Splices: 3 (or more) cable taps; such as: NSI IPCS- 2001 or 7501 (per code)
- Attachment Hardware: Use (four) screws or anchor toggle bolts, flat washers and lock washers
- ¾" hub (included with most models)
- Tools: drill & bits, mechanical knock out set, Channel Locks™, level, screwdrivers, appropriate safety equipment

## WIRING DIAGRAM

*This device is suitable for use on a circuit capable of delivering not more than 200,000 RMS symmetrical Amperes, for the respective models' (max.) nominal voltage shown in the Table of Maximum Suggested Operating Voltages on page 2.*

The SPD is equipped with integral fuses. This allows the device to be installed directly to the system bus bars, to the main lugs in a panel or disconnect, or to a circuit breaker. Consult NEC/CEC, State and Local Codes to assure compliance<sup>1</sup>.

In the event that one of the LED status indicators fail to illuminate, the entire device should be returned for warranty replacement. If service of the device is a consideration (i.e. removal and replacement), and there is no means to remove power from the SPD without removing power from the entire system, the installation should incorporate a disconnect device between the SPD and the system connecting point.

The design of these units provides superior protection for sensitive/critical equipment connected to distribution panels, sub-distribution panels or individual equipment disconnects. These units are designed for use at IEEE C62.41 Location Categories A, B, and C. "Voltage Responsive" type units are designed to be used in 50 to 420 Hz applications. NOTE: SPDs with model numbers beginning with the letter "C" are "Frequency Responsive" (Sinewave tracking) units and are designed to be used in 50 to 60 Hz applications only and shall not be used at locations where the voltage frequency fluctuates (i.e.: on the output of variable frequency drives).

When inspecting the panel prior to installation, make a visual check that there are no Neutral to Ground bonds that violate the NEC/CEC.

<sup>1</sup>[ex.: NEC '10-foot tap rule' for direct bus tapping.]

**NOTE FOR ISOLATED GROUND:** If the electrical system uses an isolated ground, connect the SPD ground to the isolated ground bus. **EXCEPTION FOR METAL ENCLOSURES AND/OR METALLIC HUBS** – For metal enclosures and/or metallic hubs, the SPD ground wire is bonded to the enclosure internally. If the system uses an isolated ground, the SPD enclosure must be isolated from the panel or load it is being connected to through the use of an insulated conduit fitting or other "Listed" fitting. In this installation, the ground wire from the SPD must terminate at the isolated ground bus.

## BEFORE INSTALLATION

**For proper performance, the SPD must be installed with the shortest lead length possible. Sharp bends should be avoided.**

No position-oriented components are used in the units. Devices can be mounted upside down or sideways allowing for shortest possible lead lengths. There are a few basic principles for surge suppression installation. They are:

1. For proper performance, the SPD must be installed with the wires as short and straight as humanly possible. Any sharp bend in the wire is unacceptable! This applies to phase, neutral, and ground leads. The objective is to reduce the lengths of wire provided on each unit, not add to it. The priority is to the phase leads, then the neutral, and then the ground lead.
2. Install the SPD on the side of the panel closest to the neutral bus, if present, and use a breaker on the same side.
3. Use a breaker close to the neutral bus and the SPD to keep the wires as short and straight as humanly possible.

The ground wire may be connected to the panel by using a ground lug installed near the SPD in the can or frame as they are grounded. (See exception above for Isolated Grounds).

## INSTALLATION DIAGRAM

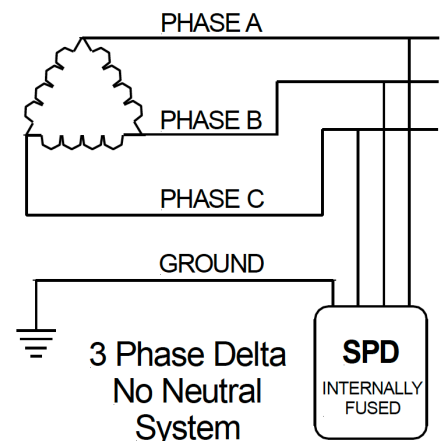

**Table of Maximum Suggested Operating Voltages and Model Wire Colors**

3-Phase DELTA Nominal System Voltage	3Nx Model Voltage Code	Phase To Phase	Phase To Ground	Phase A Wire Color	Phase B Wire Color	Phase C Wire Color	Ground Wire Color
240	3N2	264 V	264 V	Black	Black	Black	Green
480	3N4	528 V	528 V	Black	Black	Black	Green

## INSTALLATION STEPS

### STEP 1: Check Voltages

- Confirm that the nominal system voltage does not exceed the maximum suggested operating voltage for the model to be installed according to the Table above. All voltage measurements should be completed with a RMS voltmeter. **DO NOT INSTALL THE FUSED UNIT IF THE MEASURED VOLTAGE EXCEEDS THE MAXIMUM SUGGESTED OPERATING VOLTAGE OF THE DEVICE.**

**CAUTION: Do not proceed further until power has been removed from the electrical system.**

### STEP 2: Mounting the Unit

Non-lug type SPDs are provided with 18-24 inches of #10 AWG/TEW stranded wire. For best performance, mount the SPD so that all wires (phase, neutral, and ground) can be cut and connected in the shortest, straightest path possible, the goal being 6 inches of wire length or less. For every inch of conductor longer than 6-inches, you increase the let-through voltage of the SPD by 21.7 volts for an ANSI/IEEE Category B, 6 kV, 3 kA impulse and reduce the performance of the SPD.

- No sharp bends should be made in the installation. If bends are unavoidable, make them smooth and flowing. The device contains no position-dependent components; therefore, the device can be mounted upside down or sideways, etc.
- Do not cut any wires until SPD has been mounted. Units with plastic hubs must be installed with the non-metallic flexible conduit and extra hub.
- While holding the SPD on the wall, determine the shortest, straightest distance between the hub on the suppressor and hub to be installed on panel. Cut the flexible conduit to the shortest length possible to fit securely over both hubs.
- Twist the trimmed flexible conduit onto the extra hub. Slide conduit and hub over wires of SPD and twist the conduit onto the hub of the SPD.
- Connect the extra hub to the panel and mount the SPD to the wall.

### STEP 3: Connecting “Optional Form C” Dry Relay Contacts (Applies to only to SPDs with optional Dry Relay Contacts)

Make sure power is removed from surge suppressor.

- Open surge suppressor lid and note encapsulant height prior to drilling or punching enclosure. (Allow internal clearance for locknuts).
- Drill 0.5” diameter clearance hole through side, top or bottom of unit and install a watertight strain relief (i.e.: Altech #225-A00 (Part No. SR011)).
- NOTE: Surge suppressor is equipped with two sets of contacts. The first set (labeled 1 & 2, N/C) is normally closed and the other set (labeled 3 & 4, N/O) is normally open with power applied.
- Contacts are rated at 60 W (from 30 VDC @ 2 A to 150 VDC @ 0.4 A) or 100 VA (from 50 VAC @ 2 A to 220 VAC @ 0.45 A).
- Alarm contacts accept AWG #26 (0.14mm<sup>2</sup>) to AWG #16 (1.5mm<sup>2</sup>) wire. Wire size must be in compliance with NEC/CEC, State or Local codes for power on circuit. Follow rules for the class of wiring used when routing alarm leads. To maintain NEMA-4 (IP66) rating use appropriate cable and watertight strain relief.
- Connect alarm circuit(s) to Normally Open (N/O) or Normally Closed (N/C) terminals as required.
- Upon replacing front cover of suppressor, certain models allow various lid rotations (90° to 180°) for improved label orientation. (model specific)

### STEP 4: Wire the SPD into the Electrical System

- Carefully lay out the wires keeping them as short and straight as possible. (Wires may be slow-twisted together thereby reducing RF-impedance.) After a satisfactory layout has been made to the appropriate termination points as described below, cut the wires and connect them as instructed.
- Connect the GREEN ground wire from the SPD to the system ground bus bar or to a lug mounted in the can or frame close to the SPD if the Ground bus bar is not close following the current NEC/CEC. Refer to earlier sections for systems utilizing an isolated ground.
- Connect the phase wires or “hot” wires (see table above for wire colors) from the SPD to the phase conductors or buses of the electrical system through the required circuit interrupts (fuses or breakers) described above. Note that the SPD has internal fusing and does not require external circuit interrupts (external fuses or breakers). The Phase conductors may be directly connected to the phase conductors or buses after the main disconnect.
- Upon replacing front cover of suppressor, certain models allow various lid rotations (90° or 180°) for improved label orientation (model specific).

***Before energizing, measure the voltage again to ensure it is within the levels in the table above.***

***Immediate failure of the SPD will occur if installed on voltages higher than shown in the Table at the top of this page.***

### STEP 5: Apply Power to the Surge Suppressor

- The LED indicator lights should be illuminated. If they are not, remove power from the surge suppressor and contact supplier.

## LIMITED WARRANTY

Warranty service is available by either (a) returning the product to the dealer from whom the unit was purchased or (b) completing a warranty claim online at [www.Intermatic.com](http://www.Intermatic.com). This warranty is made by: Intermatic Incorporated, Customer Service 1950 Innovation Way, Suite 300, Libertyville, IL 60048.

For warranty service go to: <http://www.Intermatic.com> or call 815-675-7000