



Model T-1976

PROGRAM TIME SWITCH WITH "SKIPPER"



FOR UP TO 48 TIMING OPERATIONS
ON 24 HOUR SCHEDULE

SINGLE POLE DOUBLE THROW



SWITCH RATING: 20 AMP. 125-480 VOLTS A.C. 1/2HP-125V, 1HP-250V.
CLOCK MOTOR: 208-277 VOLTS - 60 HZ.

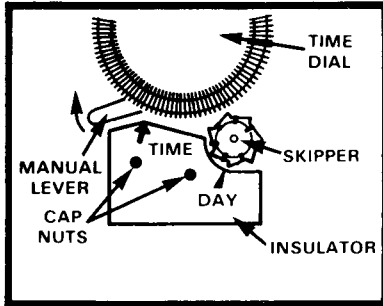
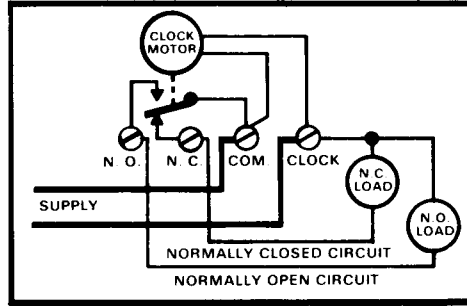

FIG. 1



WIRING DIAGRAM

WIRING INSTRUCTIONS

This Time Switch can be wired to control two circuits as Single Pole Double Throw, or to control one circuit as Single Pole Single Throw. Either normally open (NO) or normally closed (NC). To wire Time Switch as desired, see wiring diagram above.

PROGRAMMING INSTRUCTIONS

- 1. SET PROGRAM TIME:** Depress tripper(s) into dial at desired time(s) operation(s) is/are required.
ON TIME: First tripper turns on the load for 16-20 minutes. Each additional tripper will lengthen the on time by 15 minutes. If skipping of selected days is desired, the skipper tripper (silver color) should be used to initiate the first operation of the daily program, provided that there is at least 3 hours between the last operation of the previous day and the first operation of the present day.
OFF TIME: First tripper in raised position turns off the load for 10-14 minutes. Each additional space will lengthen the off time by 15 minutes.
- 2. SET TIME OF DAY:** Turn dial in clockwise direction only and align the exact time of day on dial (the time when switch is being put into operation) to the time arrow on insulator.
- 3. CHECK SKIPPER WHEEL** If switch is to function seven days a week, pull all pins, in skipper wheel up to "OUT" position. Otherwise depress pin(s) in skipper wheel for day(s) automatic operation is not required.
 - If, after the dial is set to the correct time of day, and the skipper tripper (silver color) has not yet passed the skipper wheel, turn wheel counter clockwise so that the previous day is opposite the "DAY" arrow.
 - If the skipper tripper has already passed the skipper wheel, set the correct day opposite the "DAY" arrow.

OPERATING INSTRUCTIONS

To control load(s) manually, move manual lever (See Figure 1) up. This lever will close normally open circuit and open the normally closed circuit, provided pin in skipper wheel opposite "DAY" arrow, is in "OUT" position. To return to automatic control, move lever back to its original position.

IN CASE OF POWER FAILURE, Reset dial, see steps 2 and 3 of programming instructions.

TO REMOVE MECHANISM FROM CASE, Disconnect electricity and all wiring. Depress retainer spring at upper left, or unscrew mounting screws, then grasp dial and pull mechanism out.

INTERMATIC INCORPORATED
SPRING GROVE, ILLINOIS 60081